

SKUD 18

CLASS RULES 2010

REVISED ~~JUNE~~OCTOBER 2010

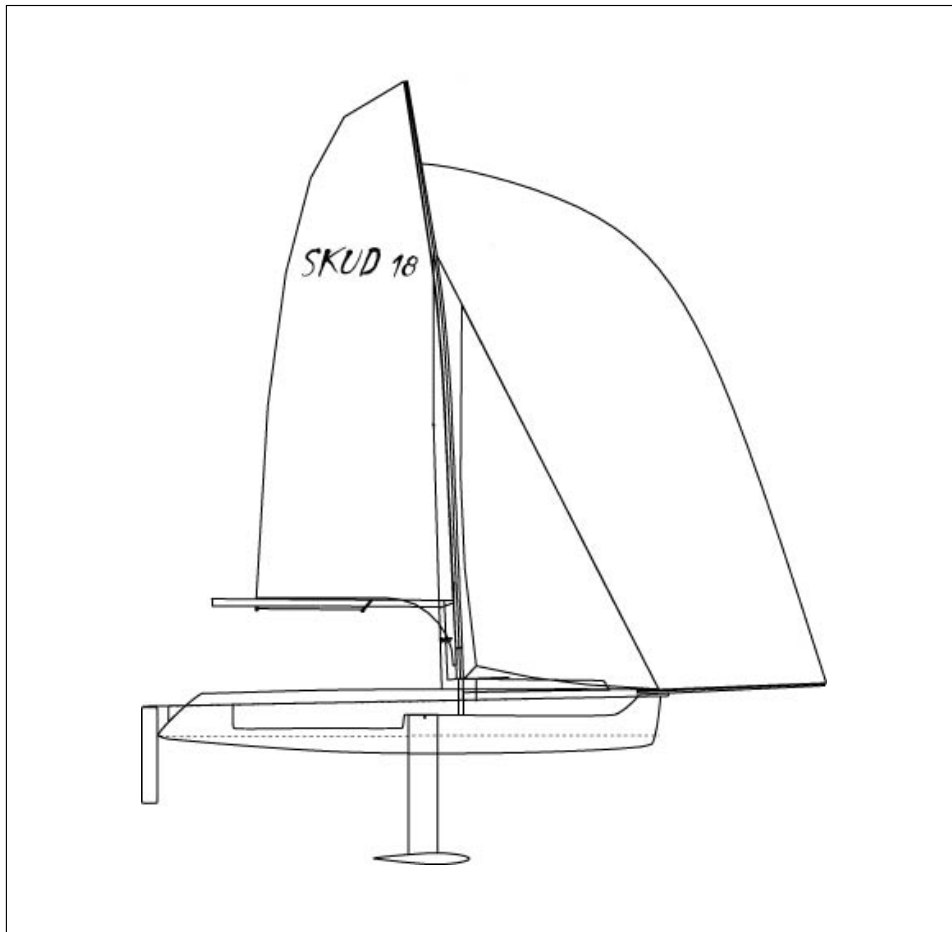

The SKUD 18 was designed in 2005 by Chris Mitchell.

INDEX

PART I – ADMINISTRATION

Section A – General

A.1	Language	4
A.2	Abbreviations	4
A.3	Authorities.....	4
A.4	Administration of the Class	4
A.5	ISAF Rules	4
A.6	Class Rules Variations	4
A.7	Class Rules Amendments	4
A.8	Class Rules Interpretation	5
A.9	International Class Fee and IFDS Building Plaque	5
A.10	Sail Numbers	5
A.11	Hull Certification	5
A.12	Change of Ownership.....	5

Section B – Boat Eligibility

B.1	Class Rules.....	5
-----	------------------	---

PART II – REQUIREMENTS AND LIMITATIONS

Section C – Conditions for Racing

C.1	General	6
C.2	Crew	6
C.3	Personal Equipment	6
C.4	Advertising	7
C.5	Portable Equipment	8
C.6	Boat	8
C.7	Hull	9
C.8	Hull Appendages.....	9
C.9	Rig	10
C.10	Sails	13

Section D– Hull

D.1	Builders	14
-----	----------------	----

Section E – Hull Appendages

E.1	Manufacturers	14
-----	---------------------	----

Section F – Rigging

F.1	Standing Rigging	14
F.2	Running Rigging	15

Section G – Sails

G.1	Parts	15
G.2	General	15
G.3	Mainsail Identification	16

PART III – APPENDICES

Section H – Parts List

H.1	Parts List	17
-----	------------------	----

Section J – Notice of Race Guide

J.1	Advice for Organisers <u>SKUD 18 Configurations</u>	19
-----	--	----

Section K – ~~Measurement Sailing~~ Instructions Guide

K.1	Measurement Certificate <u>Alternative Penalties 2019</u>	
-----	--	--

Section L – Measurement

L.1	<u>Measurement Certificate</u>	20
-----	--------------------------------------	----

Formatted: Indent: Left: 0 cm, First line: 0 cm

INTRODUCTION

SKUD 18 hulls, hull appendages, rigs and sails shall only be manufactured by builders licensed by Access Sailing Systems Pty Ltd in the class rules referred to as licensed manufacturers. Equipment is required to comply with the SKUD 18 Building Specification.

SKUD 18 hulls, hull appendages, rigs and sails may, after having left the manufacturer, only be altered to the extent permitted in Section C of the class rules.

Rules regulating the use of equipment during a race are contained in Section C of these class rules, in ERS Part I and in the Racing Rules of Sailing.

This introduction only provides an informal background and the SKUD 18 Class Rules proper begin on the next page.

PART I – ADMINISTRATION

Section A – General

A.1 LANGUAGE

- A.1.1 The official language of the class is English and in case of dispute over translation the English text shall prevail.
- A.1.2 The word “shall” is mandatory and the word “may” is permissive.

A.2 ABBREVIATIONS

- A.2.1 ISAF International Sailing Federation
- IFDS International Association for Disabled Sailing
- MNA ISAF Member National Authority
- IACA International Access Class Association
- NACA National Access Class Association
- ERS Equipment Rules of Sailing
- RRS Racing Rules of Sailing

A.3 AUTHORITIES

- A.3.1 The international authority of the class is the IACA.

A.4 ADMINISTRATION OF THE CLASS

- A.4.1 The IACA may delegate part or all of its functions, as stated in these class rules, to an NACA.

A.5 ISAF RULES

- A.5.1 These **class rules** shall be read in conjunction with the ERS.
- A.5.2 Except where used in headings, when a term is printed in “**bold**” the definition in the ERS applies and when a term is printed in “*italics*” the definition in the RRS applies.
- A.5.3 These class rules shall be considered **closed class rules** for any purpose.

A.6 CLASS RULES VARIATIONS

- A.6.1 At Class Events, ISAF Regulation 26.5(f) applies. At all other events RRS 87 applies.

A.7 CLASS RULES AMENDMENTS

- A.7.1 Amendments to these **class rules** are subject to the approval of the IFDS.

A.8 CLASS RULES INTERPRETATION

- A.8.1 Interpretation of **class rules** shall be made by the Technical Officer, subject to ratification by IACA.

A.9 INTERNATIONAL CLASS FEE AND IFDS BUILDING PLAQUE

A.9.1 The licensed hull builder shall pay the IFDS Hull Levy.

A.10 SAIL NUMBERS

A.10.1 Sail numbers shall be issued by the IACA.

A.10.2 Sail numbers shall be issued in consecutive order starting at “001”.

A.11 HULL CERTIFICATION

A.11.1 A **certificate** shall not be issued.

A.12 CHANGE OF OWNERSHIP

A.12.1 Upon disposal of a boat, the former owner shall inform the IACA of the new owner’s name, address and contact details.

Section B – Boat Eligibility

For a **boat** to be eligible for *racing*, it shall comply with the rules in this section.

B.1 CLASS RULES

B.1.1 The boat shall:

- (a) be in compliance with the **class rules**.
- (b) be crewed by at least one person who is a member in good standing of the IACA.
- (c) be defined by one set of licensed parts

PART II – REQUIREMENTS AND LIMITATIONS

The **crew** and the **boat** shall comply with the rules in Part II when *racing*. In case of conflict Section C shall prevail.

The rules in Part II are **closed class rules**. **Equipment inspection** shall be carried out in accordance with the ERS except where varied in this Part.

Section C – Conditions for Racing

C.1 GENERAL

C.1.1 RULES

(a) The ERS Part I – Use of Equipment shall apply.

(b) RRS 42 shall be amended as below:

RRS 42.3 is changed as follows:

(i) A boat's crew may pump the mainsail repeatedly to release one or more battens.

Formatted: Font color: Auto

Formatted: Indent: Left: 2.25 cm, Hanging: 0.75 cm, Numbered + Level: 1 + Numbering Style: i, ii, iii, ... + Start at: 1 + Alignment: Left + Aligned at: 2.24 cm + Indent at: 3.51 cm

Comment [DS1]: To avoid protests and penalties for "popping" battens

C.2 CREW

C.2.1 LIMITATIONS

- (a) The **crew** of a SKUD 18.2 shall consist of two (2) persons.
- (b) The **crew** of a SKUD 18.3 shall consist of three (3) persons.
- (c) No **crew** member shall be substituted during an event of less than 3 consecutive days, unless approved by the Jury.
- (d) Where centreline seats are specified or fitted, crew (buttocks) must remain in contact with their seating at all times while racing.
- (e) If one centreline seat only is fitted, one crew may use a trapeze. This changes RRS 49.1.

C.2.2 WEIGHTS

- (a) There is no restriction on the weights of the individual crew members, nor their combined weight.

C.3 PERSONAL EQUIPMENT

C.3.1 MANDATORY

- (a) The boat shall be equipped with **personal buoyancy** for each crew member to the minimum standard EN 393: 1995 (CE 50 Newtons), or USCG Type III, or AUS PFD 2.

C.3.2 OPTIONAL

- (a) Equipment inside Control Points (CP) (per C 9.8) shall not be changed to alter functionality.

Formatted: Font: (Default) Times New Roman, English (U.K.)

- (b) To compensates for a sailor's disability, a boat's running rigging and rudders may be adjusted and operated using stored power, provided this does not materially change the sailing characteristics of the boat or improve the sailor's performance beyond that of an able-bodied person. Equipment shall be approved by the Technical Committee. This changes RRS 52.
- (c) Location of control lines after the CP may be changed.

Formatted: Font: (Default) arial, sans-serif, English (U.K.)

Formatted: Font: (Default) arial, sans-serif, English (U.K.)

Formatted: Font: (Default) arial, sans-serif, English (U.K.)

Formatted: Font: (Default) arial, sans-serif, English (U.K.)

Formatted: Font: (Default) arial, sans-serif, English (U.K.)

Formatted: scheading-subrule, Indent: Left: 0 cm, Tab stops: 2.14 cm, Left

C.3.3 SEATING

~~(d)~~ Seating may be of any origin. All seating ~~must shall~~ meet the following specifications:

1. All seating must be mechanically attached to the hull on the centreline via the provided tracks in a manner to avoid separation while under sail. Their longitudinal location is optional, and ~~must shall~~ be fixed during racing.
2. There ~~must shall~~ be restraints built into the seating to keep the sailor in the seating at all angles of heel. Restraints ~~must shall~~ secure the crew to their seat at all times during racing. Buckles and release mechanisms must be of a “quick release” type and be clearly visible for fast assistance on the water.
3. Horizontal seat width (not including the back or leg rest extension) shall not exceed 500mm athwartships. Horizontal seat length shall not exceed 600mm longitudinally measured from the centre of the seat back at the sitting surface to the most forward sitting surface (ie. to the steering joystick if mounted in centre of seat). ~~Leg rests are not part of the seat length, but can be integral to the seating.~~
4. A canting mechanism which allows the sailor to remain in the vertical position relative to the horizon while sailing is permitted, limited to a maximum total rotation of +/- 25 degrees from centre. Safety mechanisms to prevent uncontrolled motion of the seat ~~must shall~~ be demonstrated. The intent of this provision is to allow for the comfort and wellbeing of a sailor and not to project weight to windward.
5. The axis of rotation for canting seats shall be along the hull centreline, parallel to the floor and not greater than 50mm below the projected intersection of the seat plane (underside of cushion) and the backrest plane, or 50mm below the seat mounting base plane. Maximum height of the sitting surface (including cushion) is 120mm above the seat plane.
6. All seating must have a backrest and sides with a minimum height above the sitting surface of 125mm. Backrest and sides shall extend for a minimum of 50% of the seat width and length respectively. The sides of ~~of canting seats shall be within 25 degrees of vertical. The sides of non-canting seats shall be within 25 degrees of vertical. Where commercially available seats are installed to meet a sailor’s individual disability, such as ‘go-kart’ seats or similar, the requirements of this sub-clause may be waived subject to approval of the Class Technical Officer.~~ The intent of ~~theseis~~ provisions is to allow for the comfort and wellbeing of a sailor and not to project weight to windward.
7. Overall seat height from the cockpit floor to the sitting surface shall not exceed 450mm. Upon application to the Class Technical Officer, an increased seat height may be allowed for individual sailors of short stature.

C.3.4 TRAPEZE ~~(e)~~

Comment [DS2]: Recommended by IACA Rules & Measurement VY Bob Schahinger & Jury Chair Peter Johnson that this section not fall under the heading “Optional”.

Formatted: Font: (Default) Times New Roman, English (U.K.)

Formatted: Font: (Default) Times New Roman, No underline, English

Formatted: Font: (Default) Times New Roman, English (U.K.)

Formatted: Font: (Default) Times New Roman, English (U.K.)

Formatted: English (U.K.)

Formatted: Font: (Default) Times New Roman, English (U.K.)

Comment [DS3]: Replacing must with shall

Formatted: Default Paragraph Font, English (U.K.)

Formatted: Font: (Default) Times New Roman, English (U.K.)

Comment [DS4]: Amended to avoid canting seats having 25 + 25 degrees

Formatted: Font color: Auto

Formatted: Font: (Default) Times New Roman, English (U.K.)

Formatted: Default Paragraph Font, English (U.K.)

Formatted: Font: (Default) Times New Roman, English (U.K.)

A single trapeze may be used as per C.2.1. The trapeze wires may be stainless steel wire of not less than 2.3 mm diameter or spectra lines of not less than 3.0 mm diameter and attach to the topmast 150mm above the hounds.

Formatted: Font: (Default) Times New Roman, English (U.K.)

Formatted: Indent: Left: 1.5 cm, First line: 0 cm, Tab stops: 1.5 cm, Left + Not at 2.22 cm

C.4 ADVERTISING

C.4.1 LIMITATIONS

Advertising shall only be displayed in accordance with the ISAF Advertising Code.

C.5 PORTABLE EQUIPMENT

C.5.1 FOR USE

- (a) OPTIONAL (not part of hull weight unless noted)
 - (1) Timing devices, and mechanical wind indicators are permitted (part of the hull weight).
 - (2) Compasses with brackets are permitted (part of the hull weight). GPS are not permitted.
 - (3) Mooring line.
 - (4) Spares and tools.
 - (5) Tuff's or ribbons in the **rigging** (part of hull weight).

C.5.2 NOT FOR USE

- (a) MANDATORY
 - (1) Towing rope, floating, minimum 15 m long of not less than 6 mm in diameter run through forestay eye (is part of hull weight).

C.6 BOAT

C.6.1 LIMITATION

- (a) **Hull, Hull Appendages and Spars** are as *supplied by a licensed manufacturer. No alteration allowed.*

C.6.2 WEIGHT

SKUD 18.2	Minimum
The weight of the boat, rig, seats and fixed adaptive aids (e.g. servos, fixed-location batteries) in dry condition All boats shall add correctors as required to reach the assigned racing minimum weight.	390 400 kg
SKUD 18.3	Minimum
The weight of the boat, rig, seats and fixed	305 315

SKUD 18.2	Minimum
adaptive aids (e.g. servos, fixed-location batteries) in dry condition All boats shall add correctors as required to reach the assigned racing minimum weight.	kg

Comment [DS5]: Weight increased

The weight shall be taken excluding **sails**, but including all portable equipment as listed in C.5.

C.6.3 CORRECTOR WEIGHTS

- (a) **Corrector weights** as required to bring a boat to the specified minimum racing weight shall be securely fastened to seat tracks and split equally across centreline.

C.6.4 FLOTATION

- (a) Removal of floatation material built into the hull is not allowed.

C.7 HULL

- (a) **Hulls and Decks** shall comply with the **building specification** in force at the time of manufacture.

C.7.1 MAINTENANCE AND REPAIR

- (a) In the event of damage to any part of the hull, necessary repairs may be made provided repairs are made in such a way that the essential shape and function is not materially affected. Fittings shall be attached in the same position as before the repair, or as close as is structurally possible.
- (b) The **hull** may be sanded and polished, except that the shape or weight distribution as originally supplied shall not be altered.

C.7.2 FITTINGS

- (a) USE
 - (1) Watertight integrity of the **hull** shall be maintained at all times.

C.7.3 LIMITATIONS

- (a) No holes may be made in the **hull** moulding, except for the purpose of making repairs.
- (b) Only holes necessary for mounting fittings or adaptive equipment may be made in the deck mouldings.
- (c) Additional mouldings, consoles or bridges are allowed as adaptive equipment required for sailors with a disability. Such additions must be approved by the Class Technical Committee. The structural characteristics of the boat shall not be altered by such equipment.
- (d) Fabric spinnaker chute covers are allowed, subject to approval by the Class Technical Committee.

C.8 HULL APPENDAGES

C.8.1 MAINTENANCE AND REPAIR

- (a) *Hull appendages shall comply with the building specification in force at the time of manufacture.*
- (b) The **hull appendages** may be sanded and polished, except that the shape or weight distribution as originally supplied shall not be altered.
- (c) Aluminium rudder foils may be coated to prevent corrosion.

C.8.2 LIMITATIONS

- (a) Only one **keel** and two **rudder** blades shall be used during an event, except when a **hull appendage** has been lost or damaged beyond repair.

C.8.3 KEEL

(a) USE

- (1) The **keel** must be fixed in position by the mechanism provided. No other location or arrangement allowed. It can not be shimmed to sit higher or the top flange altered in any way.
- (2) Tape, cloth, a polyurethane or rubber gasket, or wedges made from polyethylene or other material, can be used to prevent movement of the fin stock in the trunk provided they do not prevent the rapid removal of the fin from the trunk, or protrude from the trunk below the waterline.
- (3) Max weight of SKUD 18.2 bulb is 140kg
- (4) Max weight of SKUD 18.2 keel and bulb is 163kg
- (5) Max weight of SKUD 18.3 bulb is 60kg
- (6) Max weight of SKUD 18.3 keel and bulb is 75kg
- (7) The fore & aft keel angle at the leading edge and hull is 90 degrees with a tolerance of +/- 10mm measured horizontally 1 metre below hull.
- (8) The vertical angle of the keel bulb is 90 degrees to the leading edge measured from a projected line between end centres with a tolerance of +/- 10mm measured vertically at both end centres.
- (9) The keel bolt plugs (supplied plastic covers) are optional and may be replaced or removed and faired. Removal may be required for measurement purposes and replacement is the owner's responsibility.

C.8.4 RUDDERS

(a) USE

- (1) The rudder shall be fixed in its fully lowered position.
- (2) Both rudders must be present for racing.
- (3) A rudder tie-rod located not less than 150mm longitudinally from the centreline of the rudder pins shall connect the rudders or tiller arms. The length of the tie-rod shall not be adjusted while racing.
- (4) Rudder pin bushes may be fitted in the gudgeon plates.

C.9 RIG

C.9.1 MODIFICATIONS, MAINTENANCE AND REPAIR

- (a) *Spars shall comply with the **building specification** in force at the time of manufacture. **Rigging** shall comply with the current **class rules**.*

C.9.3 LIMITATIONS

- (a) Only one set of **spars** and standing **rigging** shall be used during an event, except with permission of the jury when an item has been lost or damaged beyond repair.

C.9.4 MAST

(a) USE

- (1) The spar shall be stepped in the mast step supplied by a licensed manufacturer in such a way that the heel is not be capable of moving more than 1 mm in any direction.
- (2) The mast heel shall be secured with a bolt in the mast step to prevent movement.

C.9.5 BOOM

(a) USE

- (1) The boom spar shall be attached to the mast spar while racing using the boom gooseneck fitting provided on the mast.
- (2) The boom support strut may be removed if the kicking strap is mounted between the boom and mast step.

C.9.6 RETRACTING BOWSPRIT

(a) USE

- (1) The bowsprit shall be capable of retracting to an extension of no more than 100mm beyond the bow when on a windward leg of the course.
- (2) The bowsprit shall be extended only when setting or flying the spinnaker.
- (3) Bowsprit extensions or 'sheet-keepers' may be fitted, but must be of a flexible material and extend no more than 150mm from the outboard end of the bowsprit.
- (4) Bowsprit extensions or 'sheet-keepers' are not part of the overall boat length.

C.9.7 STANDING RIGGING

(a) USE

- (1) Rigging links and rigging screws shall not be adjusted while racing.

(2) If the stemhead fitting has two holes, the forestay shall be located in the forward hole. If the stemhead fitting has three holes, the forestay shall be located in the centre hole of the fitting.

C.9.8 RUNNING RIGGING

(a) LIMITATIONS – Control Points are defined to limit the functionality of the running rigging, but to allow adaptations for the use of the control. Any termination of function beyond the control point is open.

(b) USE

- (1) The mainsail sheet may run inside or outside the boom. No control points are defined but the sheet or bridle shall run through a block or blocks at the aft end of the boom. The mainsheet may have one or two working ends.
- (2) The mainsail halyard can be a 1:1 or 2:1 purchase at the head of the sail. The halyard shall be through the sheave in the fitting at the top of the mast and down through the mast. The point at which the halyard exits the mast shall be the control point.
- (3) The jib sheet shall be led from the jib clew through the jib car on the jib track, and forward to at least one exit box in the foredeck which acts as the control point.
- (4) The jib halyard shall be fastened to the head of the jib, led through the exit block on the mast and down through the mast. The point at which the halyard exits the mast shall be the control point.
- (5) The spinnaker sheet and guy shall be led to the sheet blocks located aft of the shrouds on the deck of the boat. These are the control points for the sheets.
- (6) The spinnaker halyard and bowsprit setting and retractions lines shall be led from the head of the spinnaker, around a block on the mast, down the mast (internal or external), around a block that sends the line forward around a block attached to the pole extension line which is the forward control point.
- (7) The retrieval line shall run from the “pull points” in the spinnaker, down through the spinnaker sock and back to a fixed block attached to the aft bulkhead which will be the control point.
- (8) A kicking strap, if fitted between the boom and mast step, shall have purchase not exceeding 16:1 and be led to the back of the king post which acts as the control point.
A compression vang (or GNAV), if fitted on the topside of the boom, shall have purchase not exceeding 6:1 and be led through the hole in the gooseneck, which is the control point.
- (9) The mainsail clew outhaul shall be 2:1 and led to the front of boom which acts as the control point.
- (10) The mainsail Cunningham control shall be 4:1 and shall be led to the sub cockpit floor beneath the tack of the main which will be the control point.

- (11) The mainsheet bridle shall terminate or run through the eyestraps on each side of the aft deck which act as the control points. The bridle may be adjusted and cleated to allow for height adjustment only of the bridle turning block.
- (c) REPLACEMENT – Fittings may be replaced by those of another manufacturer but shall maintain the same function.

C.10 SAILS

C.10.1 MAINTENANCE AND REPAIR

- (a) **Sails** shall not be re-cut or otherwise altered from their original design. Emergency repairs are allowed, but the sail must be re-measured at the first available opportunity. Sail damage and subsequent repair may invalidate the sail from use in competition based on the opinion of the measurer at the event.

C.10.2 LIMITATIONS

- (a) Not more than 1 mainsail, 1 jib, and 1 spinnaker shall be carried aboard.
- (b) Not more than 2 mainsails, 2 jibs, and 2 spinnakers shall be used during any regatta or championship, except with the permission of the jury when a **sail** has been lost or damaged beyond repair.

C.10.3 MAINSAIL

(a) IDENTIFICATION

- (1) The national letters and sail numbers shall comply with the RRS except that the national letters and numbers shall be on the same line. Refer to Section G.3 of these **class rules**.
- (2) The national letters and sail numbers shall be wholly between the 3rd and 4th **batten pockets** from the **head** of the sail.
- (3) The national letters and sail numbers shall be approximately parallel to the **batten pockets**.
- (4) The class insignia shall be displayed only on the port side of the sail
- (5) The SKUD 18.3 shall be identified by the addition of a '3' to the class insignia.

(b) USE

- (1) The **sail** shall be hoisted on a halyard. The arrangement shall permit hoisting and lowering of the **sail** at sea. The halyard may be adjusted while racing.

C.10.4 JIB

(a) USE

- (1) The sail shall be hoisted on a halyard. The arrangement shall permit hoisting and lowering of the sail at sea. The halyard may be adjusted while racing.
- (2) RRS 50.4 Headsails shall not apply.

C.10.6 GENNAKER

(a) USE

RRS 50.4 – Headsails, shall not apply, except that for the purpose of Appendix G – Advertising, the gennaker shall be deemed a spinnaker. No advertising shall be placed within 1m of tack / head nor on the front 2 luff panels

Section D - Hull

D.1 BUILDERS

D.1.1. **Hull** builders shall be licensed by Access Sailing Systems Pty Ltd and approved by the IFDS.

Section E - Hull Appendages

E.1 MANUFACTURERS

E.1.1. Manufacturers shall be licensed by Access Sailing Systems Pty Ltd and approved by the IFDS..

Section F - Rigging

F.1 STANDING RIGGING

F.1.1 MATERIALS

(a) The standing **rigging** shall be of stainless steel.

F.1.2 DIMENSIONS

Forestay	Minimum	Maximum
Forestay length from centre of the bow fitting attachment point to Mast Datum Point (see illustration below)	None	720 mm
Forestay diameter	3.0 mm	3.2 mm
Shroud diameter	3.0 mm	3.2 mm

F.1.3 MAST DATUM POINT

The Mast Datum Point (MDP) is the most forward point of the underside of the mast plug plate (see illustration below).

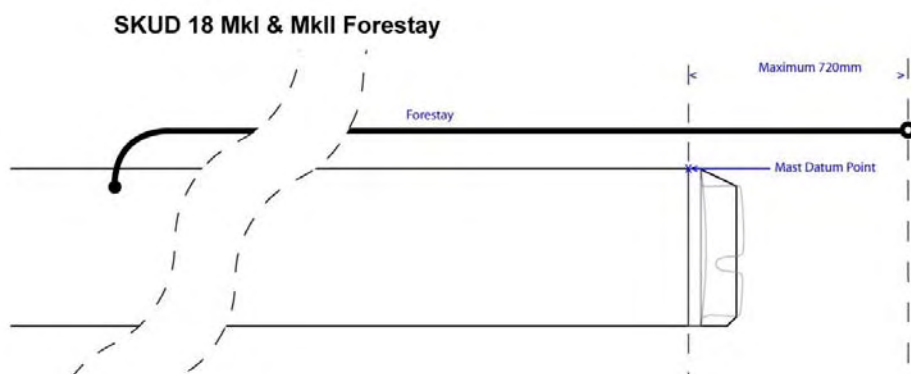

F.2 RUNNING RIGGING

F.2.1 MATERIALS

- (a) Materials are optional with regards to length, diameter and taper.
- (b) Wire is allowed for the main halyard for use with a halyard lock. No other wire is allowed.

Section G – Sails

G.1 PARTS

G.1.1 MANDATORY

- (a) Mainsail
- (b) Jib
- (c) Gennaker

G.2 GENERAL

G.2.1 RULES

- (a) **Sails** shall comply with the **class rules** in force at the time of manufacture.

G.2.4 SAILMAKER

- (a) Manufacturers shall be licensed by Access Sailing Systems Pty Ltd and approved by the IFDS.

G.3 MAINSAIL

G.3.1 IDENTIFICATION

- (a) The class insignia shall conform with the dimensions and requirements as detailed in the diagram below. (NOTE: A layout diagram and insignia graphics files are downloadable from the technical section of the class website - www.accessclass.org)



SKUD 18 Insignia - Hot Pink Pantone 812U
Insignia reads correctly from Port side

Sail Numbers & Letters - Black
Numbers & Letters read correctly from both sides

- (b) The SKUD 18.3 shall be identified by the addition of a '3' to the class insignia.



PART III – APPENDICES

The rules in Part III are **closed class rules**. Measurement shall be carried out in accordance with the ERS except where varied in this Part.

Section H

H.1.1 SKUD 18 MKI PARTS LIST

Standard fittings list (Where no comment as per class rules)	Part #	Options or restrictions
Top Mast	<i>SKUD</i> TopMast	Licensed supplier only
Mid Mast	<i>SKUD</i> MidMast	Licensed supplier only
Lower Mast	<i>SKUD</i> LowMast	Licensed supplier only
Spreader	<i>SKUD</i> Spr	Licensed supplier only
Mast Tip casting	<i>SKUD</i> TipCast	Licensed supplier only
Mast Goosneck	RM686	
Vang Foot	<i>SKUD</i> Foot	Licensed supplier only
Mast Plug	<i>SKUD</i> Plug	Licensed supplier only
Shroud Base	RM 399HD	
Boom section	<i>SKUD</i> Boom	Licensed supplier only
Boom Goosneck	RM678(m)	
Bowsprit	AS4482	Licensed supplier only
Forestay fitting	<i>SKUD</i> FS,Chain	Licensed supplier only
Mast Step Channel	<i>SKUD</i> MastStep	Licensed supplier only
Gennaker Sock	<i>AS4696</i>	Modification or replacement with an item of similar function permitted
Rudder Pin	<i>AS3402.1</i>	Varying diameters permitted
Rudder Gudgeon Top	<i>AS2391.1</i>	Licensed supplier only
Rudder Gudgeon Bottom	<i>AS2391.2</i>	Licensed supplier only
Rudder	<i>SKUD</i> Rudder	Licensed supplier only
Keel Fin	<i>SKUD</i> Fin	Licensed supplier only
Bulb	<i>SKUD</i> Bulb	Licensed supplier only
Hull	<i>SKUD</i> Hull	Licensed supplier only

H.1.2 SKUD 18 MKII PARTS LIST

Standard fittings list (Where no comment as per class rules)	Part #	Options or restrictions
Lower Mast	AS4191.1	Licensed supplier only
Upper Mast	AS4191.2	Licensed supplier only
Spreader	AS4191.3	Licensed supplier only
Masthead Fitting	AS4191.8	Licensed supplier only
Mast Plug	AS4191.7	Licensed supplier only
Chainplates	AS2382	Licensed supplier only
Boom	AS4291	Licensed supplier only
Bowsprit	AS4482	Licensed supplier only
Bow Fitting	AS2397	Licensed supplier only
Mast Step	AS2383	Licensed supplier only
Gennaker Sock	AS4696	Modification or replacement with an item of similar function permitted
Rudder Pin	AS3493	Varying diameters permitted
Rudder Gudgeon Top	AS2391.1	Licensed supplier only
Rudder Gudgeon Bottom	AS2391.2	Licensed supplier only
Rudder Blade	AS3381	Licensed supplier only
Rudder Box	AS3490	Licensed supplier only
Keel Fin	AS3192	Licensed supplier only
Keel Keel Lock	AS2386	Licensed supplier only
18.2 Bulb	AS3282	Licensed supplier only
18.3 Bulb	AS3291	Licensed supplier only
Hull	AS1090.1	Licensed supplier only

Section J - NOTICE OF RACE GUIDE

Event Notices of Race may state in which configurations the SKUD 18 shall be sailed:

J.1. Open Two Person - SKUD 18.2. Two crew can hike, or if one sits in a centreline seat one can trapeze.

J.2. Open Three Person - SKUD 18.3. Three crew can hike, or if one sits in a centreline seat one can trapeze

J.3. Open Two Person Centreline - SKUD 18.2. Two crew both in centreline seats

J.4. IFDS Two Person - SKUD 18.2. Two crew both in centreline seats, with additional provisions specified by IFDS.

Section K – SAILING INSTRUCTIONS GUIDE

K.1 ALTERNATIVE PENALTIES

Event Sailing Instructions should include the following:

For the SKUD 18 class, rule 44.1 is changed so that only one turn, including one tack and one gybe, is required

Formatted: Font: (Default) arial, sans-serif, 12 pt, English (U.K.)

~~Section K - MEASUREMENT CERTIFICATE~~

Section L - MEASUREMENT CERTIFICATE

Effective: June 1, 2010

Previous issues: August, 2007, March 2008 & July 2008

© ISAF 2007